

TITANIUM WATER SOFTENERS

BEST IN CLASS

Titanium is a high flow rate monoblock water softener designed for households with high water consumption. With a capacity of up to 3.0 m³/h, it reliably softens water for families of up to 12 people.



**ECOLITE
ULTRASOFT
INSIDE**

KEY FEATURES

- High flow rate up to 3,0 m³/h* thanks to uniform ECOLITE ULTRASOFT ion-exchange resin
- Reduces hardness and extends the life of household appliances
- Ideal for families with up to 12 members
- Trouble-free operation thanks to premium US components and featuring the Ecosoft CE valve

COMPONENTS



Softener

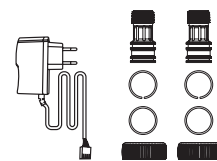

Power adaptor
Valve connection kit 3/4"
Male BSPT

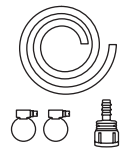

Drain & Overflow hoses
Metal Clamps
Drain Fitting



Built-in mixing
valve

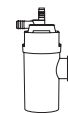

Siphon



Total hardness test

Control valve

Ecosoft CE

- Multilingual menu (EN, DE, FR, NL, IT, PL, UA)
- Auto settings
- Built-in mixing valve
- Able to add dealer information
- Screen backlight

TITANIUM WATER SOFTENERS

Code	Description	Resin, L	Pallet quantity, pcs
FU1035CABCEMVTA	Ecosoft Titanium 300 water softener 3rd generation	30	5

* Feed water hardness of 250 ppm CaCO₃

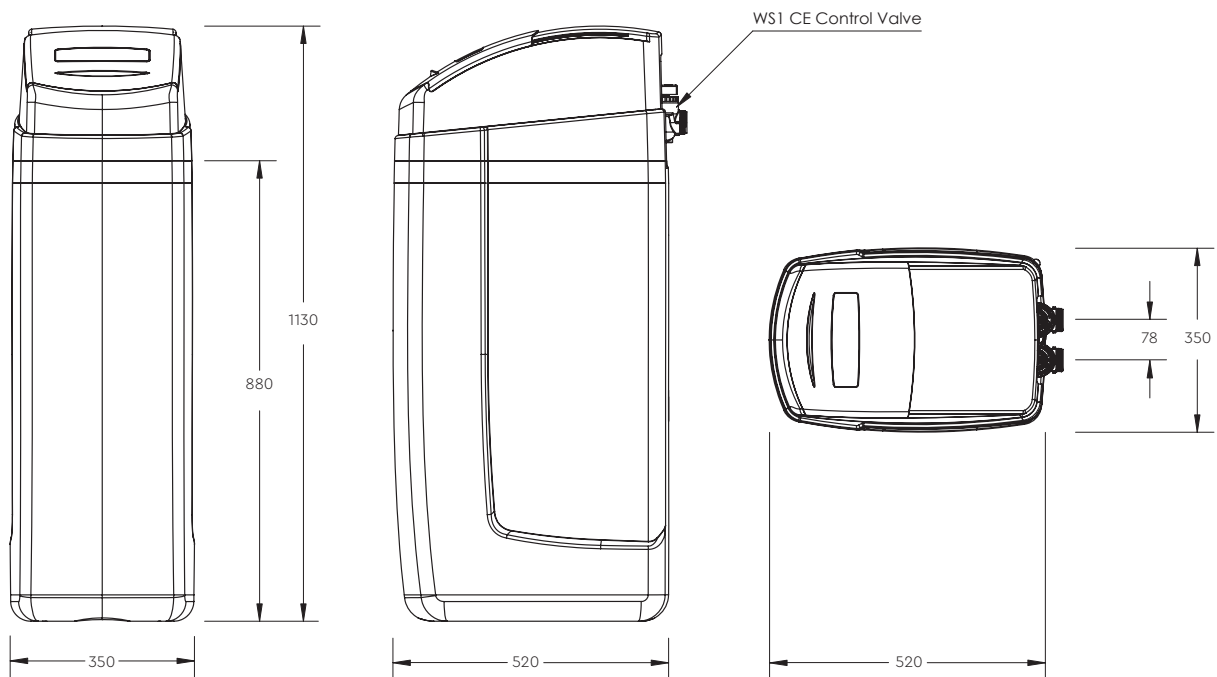

TECHNICAL SPECIFICATION

Parameter	FU1035CABCEMVTA
Operating flow rate, m ³ /h	2.0 / 3.0
Quantity of resin, L	30
Volume capacity, m ³ 250 mg/L CaCO ₃ influent harness	6
Usage of salt per regeneration, kg	3.0-4.2
Usage of water per regeneration (discharge per regeneration), m ³	0.3
Duration of regeneration, minutes	80-110
Pressure drop in service mode, bar	0.5
Inlet pressure, bar	2-6
Electrical requirements	230 V, 50 Hz
Power consumption, W	30
Inlet/outlet pipe connections	3/4"
Dry weight, kg	30
Overall dimensions, (Width × Depth × Height), mm	350 × 520 × 1130

INFLUENT WATER LIMITATIONS

Parameter	
Hardness	750 mg/L CaCO ₃
Iron	0.2 mg/L
Manganese	0.05 mg/L
Chemical Oxygen Demand	5 mg/L O ₂
Ammonium	4 mg/L
Sediment prefilter rating	100 μm
Temperature of water	+4...+30 °C