



**Product name** High flow Ecosoft HF-4040 reverse osmosis membrane

**Description** High rejection **extra-low pressure** Ecosoft 4" HF-4040 membrane for 4" commercial reverse osmosis systems. It is recommended to use this membrane with feed water TDS up to 1500 mg/l<sup>1</sup>.

**Features** Ecosoft HF membranes offer **high permeate flow rate and efficiency**, they operate at **very low pressure**. Ecosoft HF membranes are manufactured using technology that ensures long-term and reliable system operation.

**Areas of application** Water purification in private homes, production of drinking water, beverages, breweries, livestock and poultry farms, aquaculture, greenhouses, mist humidification systems, laundries, food industry.

<sup>1</sup> At a temperature of 12°C, the permeate TDS will be approximately 100 mg/l, for Ecosoft RO systems with a system efficiency of 75%.

**Typical properties**

Product	Active area (m <sup>2</sup> )	Permeate flow rate (m <sup>3</sup> /day) **	Stabilized salt rejection (%) *	Minimum salt rejection (%) *	Spacer thickness (mm)
HF-4040	7,9	10,2	98	97,5	34

\* Permeate flow rate and salt retention are given for the following test conditions: 500 mg/l NaCl, 25°C, permeate yield 15%, applied pressure 6,9 bar.  
 \*\* Permeate flow rate for a single element may vary by ±15% from the values shown.  
 \*\*\* Product specifications may be subject to minor changes due to product improvements.

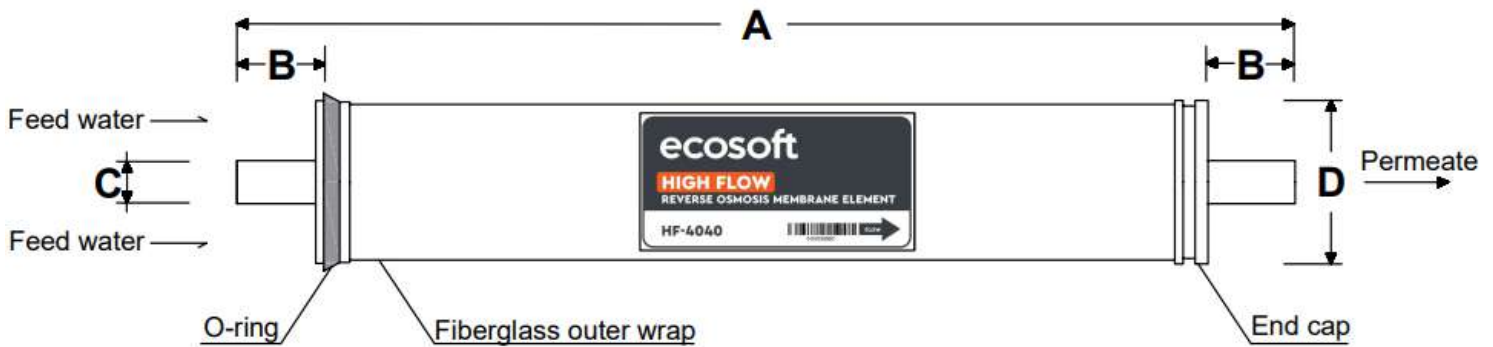

Product	Dimensions, mm			
	A	B	C	D
HF-4040	1016	26,7	19	99

**Operating conditions restrictions**

Membrane type	Polyamide Thin-film Composite
Maximum operating temperature <sup>1</sup>	45°C
Maximum operating pressure	41 bar
Maximum pressure drop	1,0 bar
pH range, continuous operation <sup>1</sup>	3-10
pH range, short-term cleaning (30 min) <sup>2</sup>	2-12
Maximum SDI	SDI 5
Free chlorine tolerance <sup>3</sup>	<0,1 mg/l

<sup>1</sup> The maximum temperature for continuous operation with pH above 10 is 35°C.

<sup>2</sup> See cleaning manual in specifications.

<sup>3</sup> Under certain conditions, the presence of free chlorine and other oxidants will cause premature membrane failure. Since damage due to oxidation is not covered by the warranty, ECOSOFT recommends removing residual chlorine during the pre-treatment stage, before it reaches the membranes.

## Important information

Proper start-up of reverse osmosis systems is essential to prepare the membranes for operation and prevent damage due to overload or hydraulic shock. Following the proper start-up sequence also helps ensure that the system is operating within the design specifications, allowing you to achieve desired water quality and system performance. Before starting the reverse osmosis system, the following checks should be performed: start-up procedure, membrane pretreatment, membrane element installation, instrument calibration. Please refer to the Ecosoft Commercial Reverse Osmosis System Operation Manual for more information.

- Theoretical performance can be determined from the schedule, see page 3.
- How to insert the membrane element into the reverse osmosis system is shown on page 5.
- Only glycerine is permitted for lubrication. The use of any other lubricant will cause permanent damage to the membrane.
- It is essential to follow the approved start-up procedure to prevent membrane damage due to overfilling or hydraulic shock.
- Prior to system start-up, reverse osmosis element installation, instrument calibration, membrane pretreatment, and other system checks must be performed.
- Always minimize any pressure surge or cross-flow fluctuations on the spiral elements.
- A gradual transition from idle to operating mode is recommended during start-up.
- The maximum pressure drop across the entire tank (housing) is 3.4 bar.
- No static pressure is allowed on the permeate side.
- After initial wetting, the elements must always be wet.
- Failure to follow the operating limitations and instructions will void the limited warranty.
- In the event of a prolonged system shutdown, it is recommended to immerse the membrane elements in a preservative solution to prevent bacterial growth.
- Permeate collected during the first hour of operation should be disposed of.
- The customer is responsible for ensuring that chemicals and lubricants do not adversely affect the reverse osmosis elements.

Note: The use of this product alone does not necessarily guarantee the removal of cysts and pathogens from water. Effective reduction of cysts and pathogens depends on the overall system design, operation and maintenance of the system.

Note: This product should not be assumed to be free from any patents owned by Seller or others. Since conditions of use and applicable laws may vary from region to region and may change over time, Customer is responsible for determining whether the products and information in this document are suitable for Customer's use and for ensuring that Customer's workplace and disposal practices comply with applicable laws and other governmental regulations. Seller assumes no liability or responsibility for the information in this document.

**IF THE OPERATING CONDITIONS AND RECOMMENDATIONS LISTED IN THIS DOCUMENT ARE NOT FOLLOWED, THE WARRANTY WILL NOT BE VALID AND WILL BE VOID.**

## Flow rate charts for Ecosoft HF-4040 membranes in MO6500, MO12000, MO24000, MO36000 commercial reverse osmosis systems\*

Permeate flow rate is calculated under the following conditions:

- inlet water pressure 2 bar;
- backpressure in the permeate line 0 bar;
- new membranes;
- inlet water salinity in mg/l as NaCl.

\*Your system performance may differ from the graph depending on water chemistry and other factors.

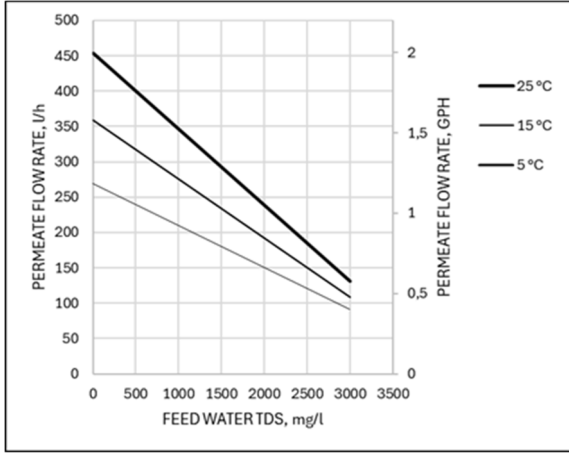

Ecosoft MO6500 flow rate chart

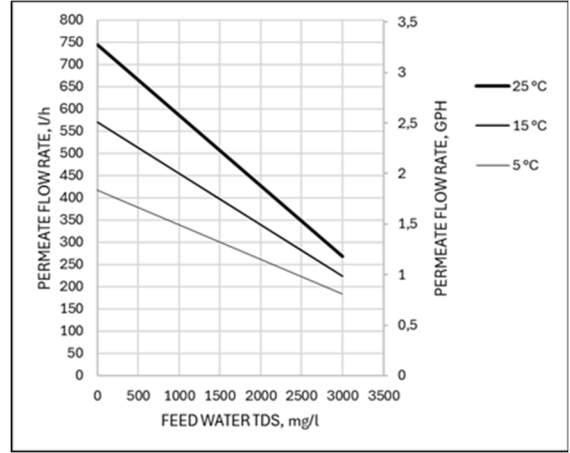

Ecosoft MO12000 flow rate chart

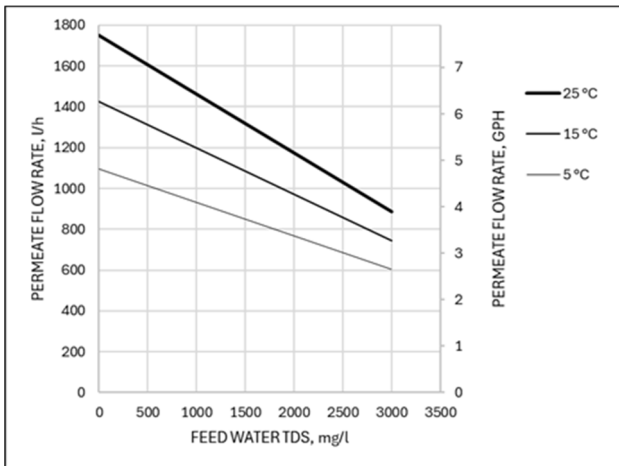

Ecosoft MO24000 flow rate chart

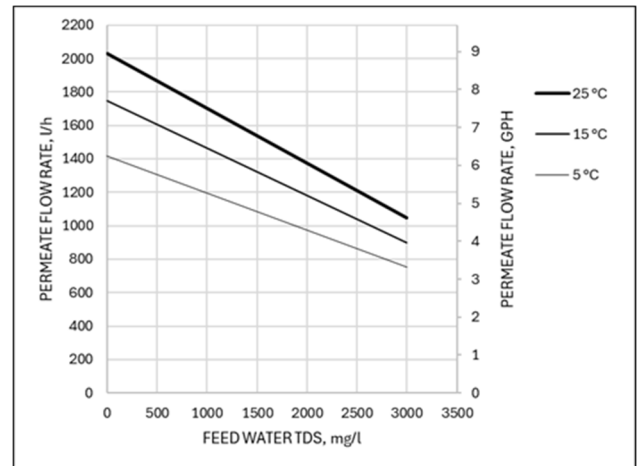

Ecosoft MO36000 flow rate chart

**Example:** Determining the theoretical permeate flow rate of the MO12000 system.

To calculate the permeate flow rate of the MO12000 system at a temperature of 15°C and a salinity of 1500 mg/l, on the FEED WATER TDS axis, we set point 1, which corresponds to a salinity of 1500 mg/l. From point 1 we draw a line to the permeate flow rate-TDS curve, at a temperature of 15°C and at the intersection we set point 2. From point 2, we draw a line to the PERMEATE FLOW RATE axis and set point 3. Theoretical permeate flow rate is 400 l/h.

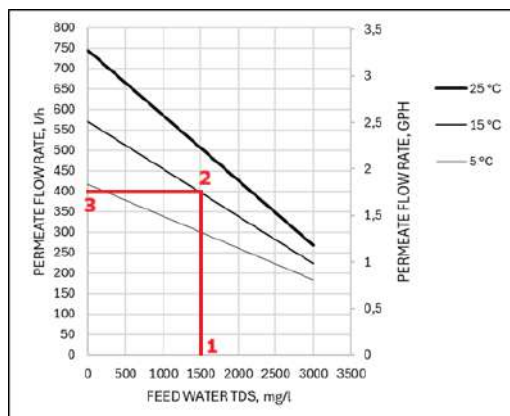

## Membrane installation

Remove the membrane element(s) from the factory packaging and install it/them into the membrane holder(s). To do this, disconnect the pipelines and remove the membrane holder(s) from the frame. Install the membrane element in the direction of the arrow marked on the membrane holder (from the inlet water side) after removing the end cap. The membrane element should be inserted into the membrane holder with the sealing ring of the membrane element aligned with the inlet connection of the membrane holder's head. After installing the membrane element, secure the membrane holder's head with screws and fixing elements to the membrane holder body, then reconnect the pipelines for water supply, concentrate discharge, and permeate outlet to the membrane holder. Fix the membrane holder to the reverse osmosis system frame. During the first system startup, the initial portion of permeate must be discharged to the sewer. The minimum discharge time for the first portion of permeate is 15 minutes.

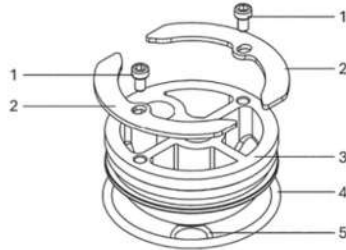

1 – screws, 2 – locking kit segments, 3 – end cap, 4 – end cap sealing ring, 5 – end cap sealing ring

### Correct membrane installation position for Ecosoft systems

The direction of the arrow on the membrane holder **must correspond** to the direction of the arrow on the membrane.

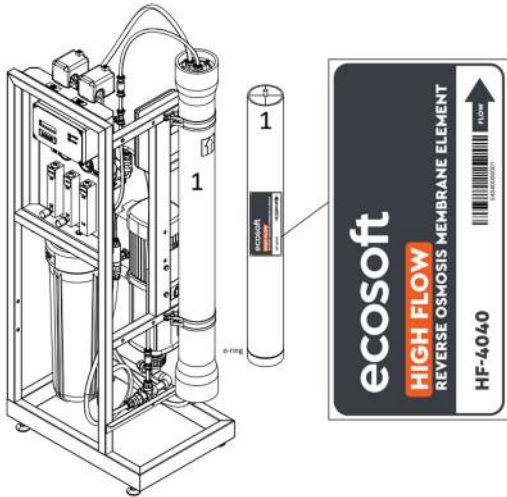

MO6500

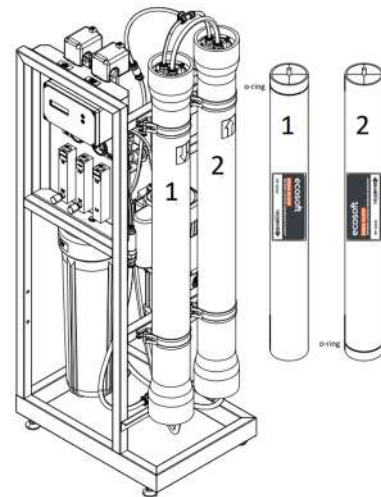

MO12000

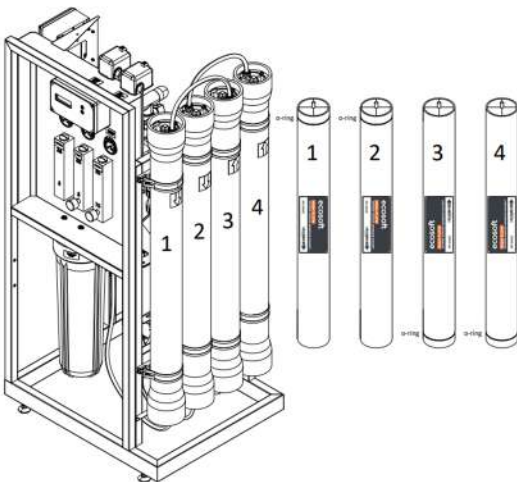

MO24000

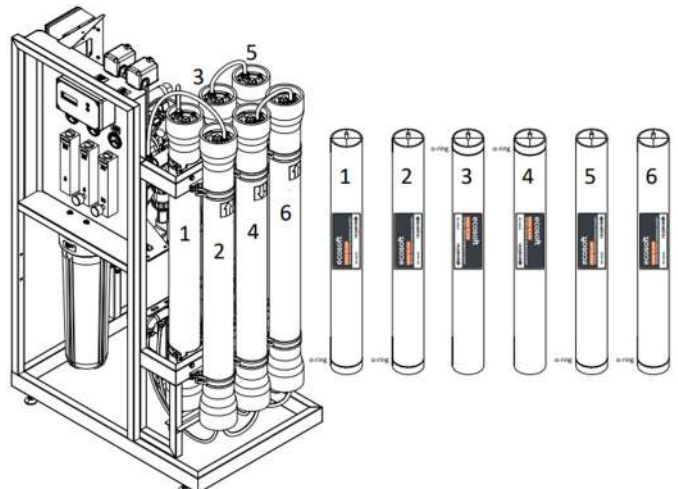

MO36000