



Product name

High flow Ecosoft HF-8040-440 reverse osmosis membrane

Description

High rejection **extra-low pressure** Ecosoft HF-8040-440 membrane for 8” industrial reverse osmosis systems. It is recommended to use this membrane with feed water TDS up to 1500 mg/l¹.

Features

Ecosoft HF membranes offer **high permeate flow rate and efficiency**, they operate at **very low pressure**. Ecosoft HF membranes are manufactured using technology that ensures long-term and reliable system operation.

Areas of application

Water purification for steam and hot water boilers, production of drinking water, beverages, breweries, livestock and poultry farms, aquaculture, greenhouses, conservatories, mist humidification systems, laundries, food industry.

¹ At a temperature of 12°C, the permeate TDS will be approximately 100 mg/l, for Ecosoft RO systems with a system efficiency of 75%.

Typical properties

Product	Active area (m ²)	Permeate flow rate (m ³ /day) **	Stabilized salt rejection (%) *	Minimum salt rejection (%) *	Spacer thickness (mm)
HF-8040-440	40,9	53,0	98	97,5	28

* Permeate flow rate and salt retention are given for the following test conditions: 500 mg/l NaCl, 25°C, permeate yield 15%, applied pressure 6,9 bar.

** Permeate flow rate for a single element may vary by ±15% from the values shown.

*** Product specifications may be subject to minor changes due to product improvements.

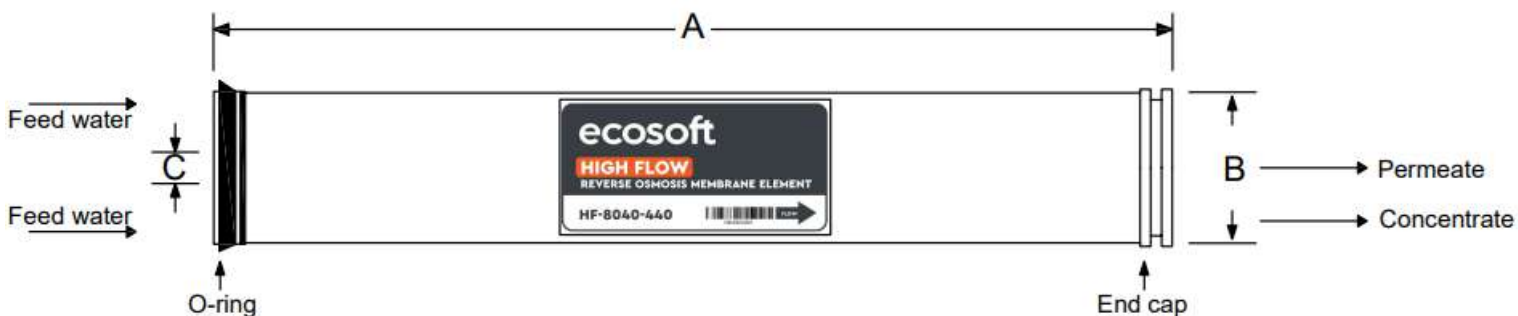

Product	Dimensions, mm		
	A	B	C
HF-8040	1016	201	29

Operating conditions restrictions

Membrane type	Polyamide Thin-film Composite
Maximum operating temperature ¹	45°C
Maximum operating pressure	41 bar
Maximum pressure drop	1,0 bar
pH range, continuous operation ¹	3-10
pH range, short-term cleaning (30 min) ²	2-12
Maximum SDI	SDI 5
Free chlorine tolerance ³	<0,1 mg/l

¹ The maximum temperature for continuous operation with pH above 10 is 35°C.

² See cleaning manual in specifications.

³ Under certain conditions, the presence of free chlorine and other oxidants will cause premature membrane failure. Since damage due to oxidation is not covered by the warranty, ECOSOFT recommends removing residual chlorine during the pre-treatment stage, before it reaches the membranes.

Important information

Proper start-up of reverse osmosis systems is essential to prepare the membranes for operation and prevent damage due to overload or hydraulic shock. Following the proper start-up sequence also helps ensure that the system is operating within the design specifications, allowing you to achieve desired water quality and system performance. Before starting the reverse osmosis system, the following checks should be performed: start-up procedure, membrane pretreatment, membrane element installation, instrument calibration. Please refer to the Ecosoft Commercial Reverse Osmosis System Operation Manual for more information.

- Theoretical performance can be determined from the schedule, see page 3.
- How to insert the membrane element into the reverse osmosis system is shown on page 5.
- Only glycerine is permitted for lubrication. The use of any other lubricant will cause permanent damage to the membrane.
- It is essential to follow the approved start-up procedure to prevent membrane damage due to overfilling or hydraulic shock.
- Prior to system start-up, reverse osmosis element installation, instrument calibration, membrane pretreatment, and other system checks must be performed.
- Always minimize any pressure surge or cross-flow fluctuations on the spiral elements.
- A gradual transition from idle to operating mode is recommended during start-up.
- The maximum pressure drop across the entire tank (housing) is 3.4 bar.
- No static pressure is allowed on the permeate side.
- After initial wetting, the elements must always be wet.
- Failure to follow the operating limitations and instructions will void the limited warranty.
- In the event of a prolonged system shutdown, it is recommended to immerse the membrane elements in a preservative solution to prevent bacterial growth.
- Permeate collected during the first hour of operation should be disposed of.
- The customer is responsible for ensuring that chemicals and lubricants do not adversely affect the reverse osmosis elements.

Note: The use of this product alone does not necessarily guarantee the removal of cysts and pathogens from water. Effective reduction of cysts and pathogens depends on the overall system design, operation and maintenance of the system.

Note: This product should not be assumed to be free from any patents owned by Seller or others. Since conditions of use and applicable laws may vary from region to region and may change over time, Customer is responsible for determining whether the products and information in this document are suitable for Customer's use and for ensuring that Customer's workplace and disposal practices comply with applicable laws and other governmental regulations. Seller assumes no liability or responsibility for the information in this document.

IF THE OPERATING CONDITIONS AND RECOMMENDATIONS LISTED IN THIS DOCUMENT ARE NOT FOLLOWED, THE WARRANTY WILL NOT BE VALID AND WILL BE VOID.

Flow rate charts for Ecosoft HF-8040 membranes in MO2, MO3, MO4, MO6, MO9 industrial reverse osmosis systems*

Permeate flow rate is calculated under the following conditions:

- inlet water pressure 2 bar;
- backpressure in the permeate line 0 bar;
- new membranes;
- inlet water salinity in mg/l as NaCl.

*Your system performance may differ from the graph depending on water chemistry and other factors.

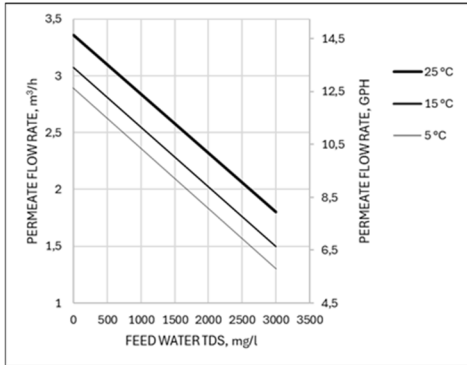

Ecosoft MO2 flow rate chart

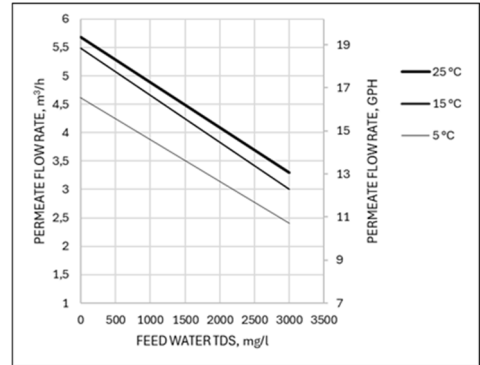

Ecosoft MO3 flow rate chart

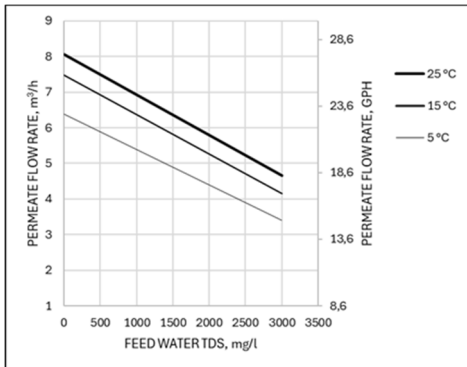

Ecosoft MO4 flow rate chart

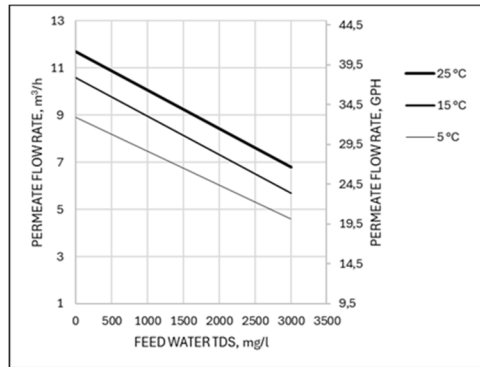

Ecosoft MO6 flow rate chart

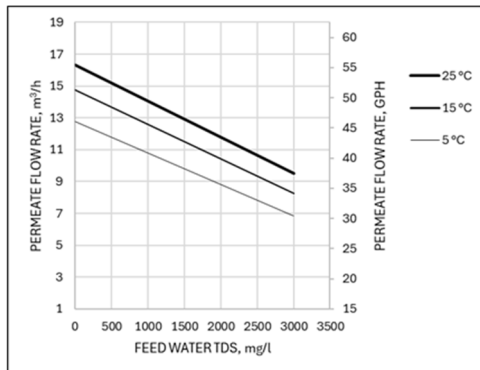

Ecosoft MO9 flow rate chart

Example: Determining the theoretical permeate flow rate of the MO3 system

To calculate the permeate flow rate of the MO3 system at a temperature of 25°C and a salinity of the feed water of 1500 mg/l, consider the graph “Permeate productivity of the Ecosoft MO3 unit”, on the FEED WATER TDS axis, we set point 1, which corresponds to a salinity of 1500 mg/l. From the point, we draw a line to the permeate flow rate-TDS curve, at a temperature of 25°C, and at the intersection, we set point 2. From point 2, we draw a line to the PERMEATE FLOW RATE axis and set point 3. Theoretical flow rate is 4.5 m³/h.

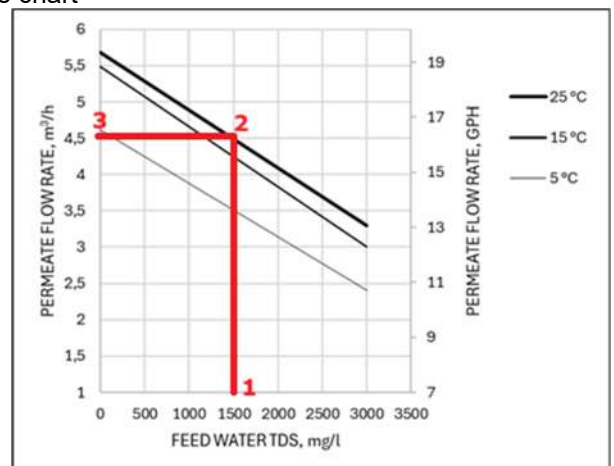

Membrane installation

Remove the membrane element(s) 5 from the factory packaging and install in the membrane housing(s) 6. To install the membrane element, remove the end cover. If you have a MO4, MO6 or MO9 system with membrane holders in which more than one membrane element needs to be installed, you must install the membrane connector 8 between the elements, as shown in the figure. To install the membrane element in the membrane holder, you must connect the membrane element sealing ring to the inlet connection of the membrane holder head, as shown in the figure. The sealing ring must be in the opposite direction to the direction of the arrow. After installing the membrane element, install the end cover 3 and secure the membrane holder heads with the fixing elements 2 and screws 1 to the membrane holder body. The screws are unscrewed with an 8 mm diameter hexagon. On the other side of the membrane holder, install the thrust ring 7, as shown in the figure, then install the adapter 4. After that, install the end cover 3 and fix the membrane holder heads with the fixing elements 2 and screws 1. Connect the water supply and concentrate and permeate discharge pipelines to the membrane holder, fix the membrane holder on the reverse osmosis system frame. When the system is first started, the first portion of permeate must be discharged into the sewer. The minimum time for discharging the first portion of permeate is 60 minutes. The connecting elements are supplied complete with the reverse osmosis membranes. The adapters are supplied together with the reverse osmosis system. The direction of the arrow on the membrane holder corresponds to the direction of the incoming water flow.

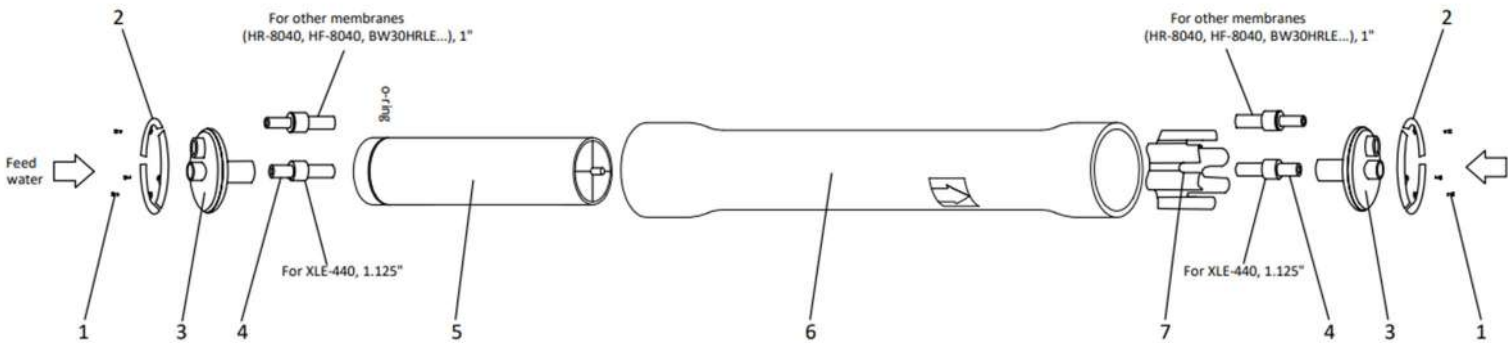

1 – screws, 2 – locking kit segments, 3 – end cap, 4 – adapter, 5 – membrane, 6 – membrane housing,
7 – thrust ring

Exploded view of the membrane housing assembly for Ecosoft MO1, MO2, MO3 reverse osmosis systems

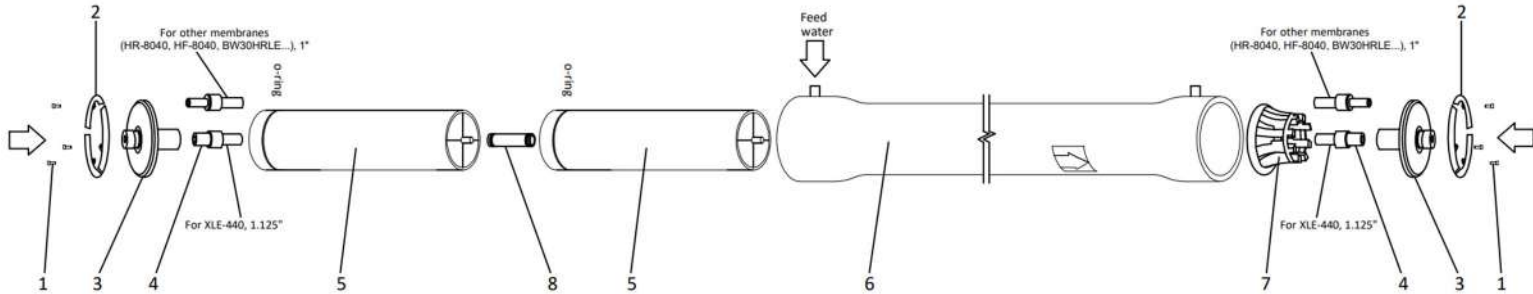

1 – screws, 2 – locking kit segments, 3 – end cap, 4 – adapter, 5 – membrane, 6 – membrane housing,
7 – thrust ring, 8 – membrane connector

Exploded view of a membrane housing with several membrane elements of Ecosoft MO4, MO6, MO9 systems

Correct membrane installation in Ecosoft systems

Arrow direction on the membrane holder **must correspond** to the direction of the arrow on the membrane element.

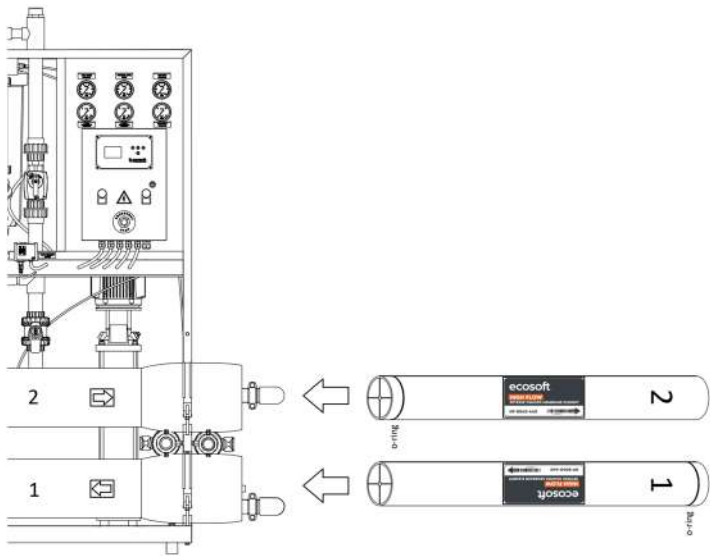

MO2

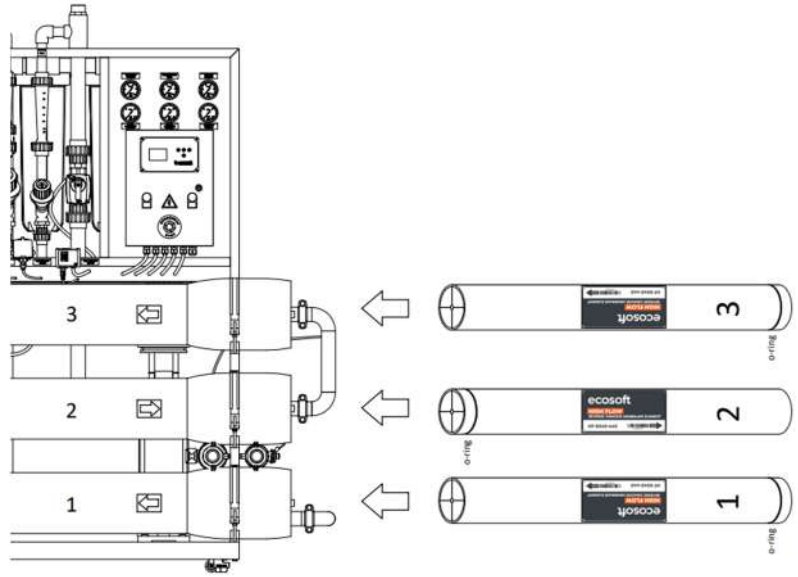

MO3

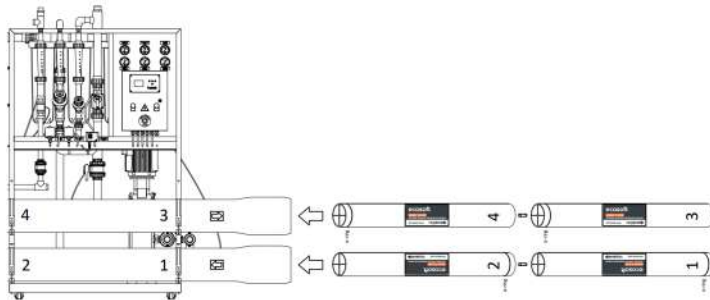

MO4

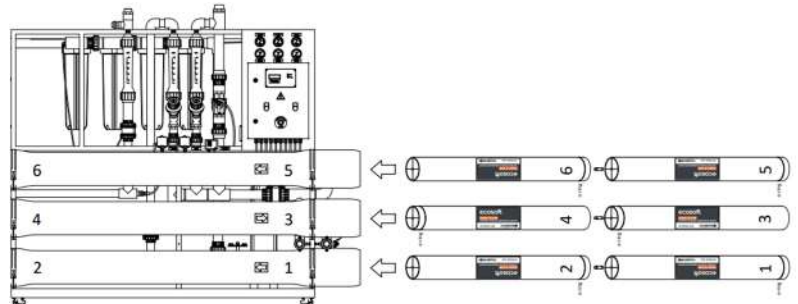

MO6

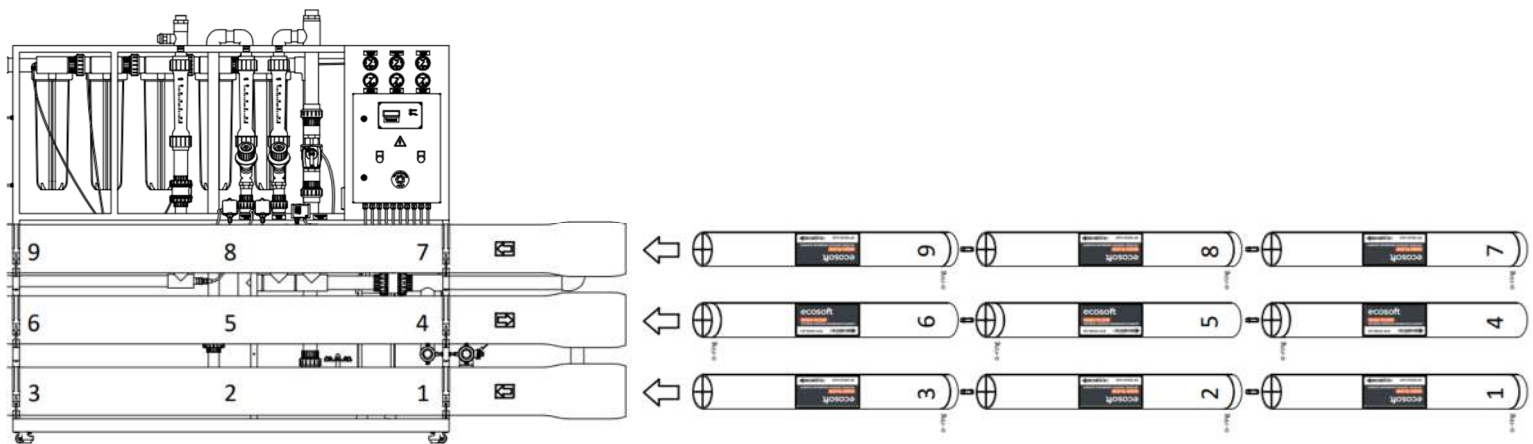

MO9