

TITANIUM AZURE SOFTENERS

These softeners provide capacity up to 3 m³ of water per hour.
The highest flow rate on the market in a compact design cabinet.

Clack® CE valve inside enables both friendly programming and advanced adjustment to fit domestic or commercial applications.

KEY FEATURES

- Made in Belgium with 100% US-made equipment
- Versatile modern Ecosoft CE control valve multilingual menu (EN, DE, FR*, NL*, IT*, PL*, UA)
- Built-in mixing valve
- Fits up to 117 kgs of salt – 9 months till next salt refill
- Smart overflow location saves installation space and protects against mechanical damage

COMPONENTS

- Pre-adjusted Ecosoft-Clack CE
- Cabinet enclosure
- Pressure tank
- Brine well with safety float valve

Control valve

Ecosoft CE

- Multilingual menu
- User-friendly and auto settings
- Built-in mixing valve
- Able to add dealer information
- Screen backlight



TITANIUM AZURE SOFTENERS

Code	Description	Resin, L	Pallet quantity, pcs.
FU0835CABCEMVTA	Titanium Azure 180 water softener	18	5
FU1035CABCEMVTA	Titanium Azure 250 water softener	25	5
FU1235CABCEMVTA	Titanium Azure 370 water softener	37	5

* Will available from Q3 2025

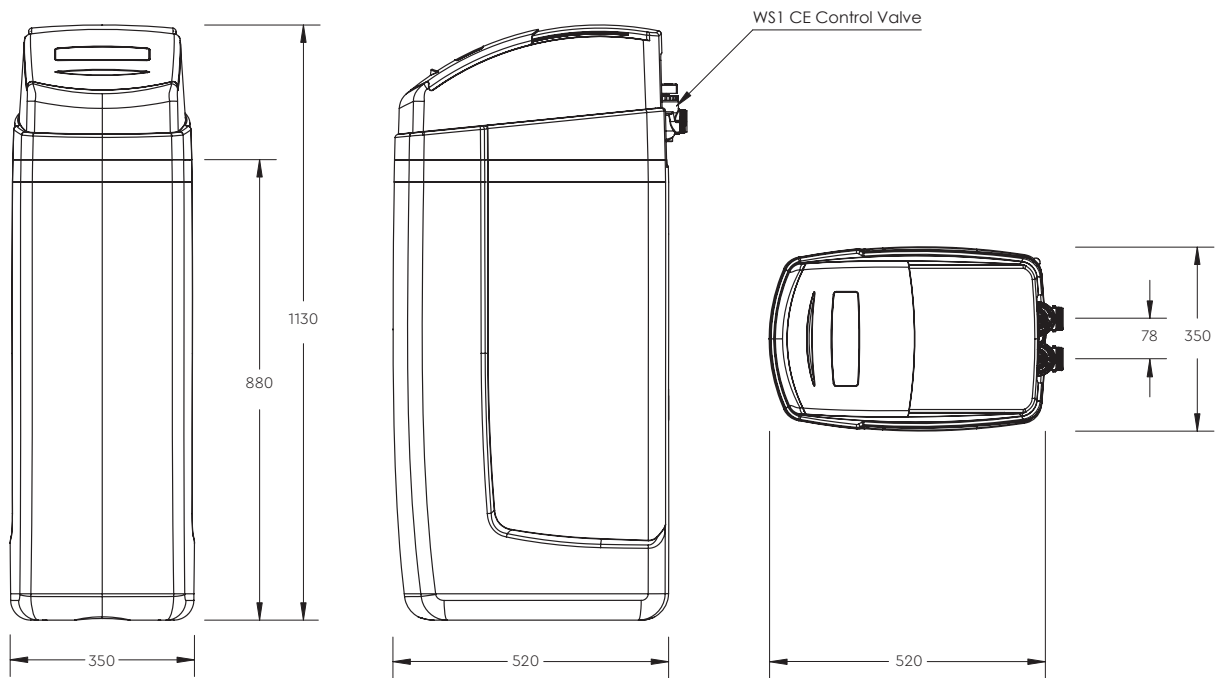

TECHNICAL SPECIFICATION

Parameter	FU0835CABCEMVTA	FU1035CABCEMVTA	FU1235CABCEMVTA
Operating flow rate, m ³ /h	1.0 / 1.3	1.5 / 2.0	2.2 / 2.8
Quantity of resin, L	18	25	37
Volume capacity, m ³ 250 mg/L CaCO ₃ influent harness	3.6	5	7.5
Usage of salt per regeneration, kg	1.8-2.9	2.5-4.0	3.7-6.0
Usage of water per regeneration, m ³	0.18	0.25	0.37
Duration of regeneration, minutes		80-110	
Pressure drop in service mode, bar		0.5	
Inlet pressure, bar		2-6	
Electrical requirements		230 V, 50 Hz	
Power consumption, W		30	
Inlet/outlet pipe connections		3/4"	
Dry weight, kg	24	30	42
Overall dimensions, (Width × Depth × Height), mm		350 × 520 × 1130	

INFLUENT WATER LIMITATIONS

Parameter	
Hardness	750 mg/L CaCO ₃
Iron	0.2 mg/L
Manganese	0.05 mg/L
Chemical Oxygen Demand	5 mg/L O ₂
Sediment prefilter rating	100 μm
Temperature of water	+4...+30 °C